



www.lascells.com

**MKIII
RIPPLE-STROBE
TANK**

LA50-600

INSTRUCTIONS FOR USE

MKIII RIPPLE-STROBE TANK

LA50-600

INTRODUCTION:

This apparatus provides a simple and effective method for students to investigate the properties of waves. The tank is completely self contained, requiring no setting-up apart from the addition of water, and incorporates a built-in stroboscope to provide stationary or slowly moving images.

APPLICATIONS

- Properties of water waves
- Properties of waves in general
- Diffraction, refraction, reflection and interference

GENERAL DESCRIPTION:

Waves are generated in a small, rectangular tank which is placed on a raised shelf over the internal illumination source. The wave generator is built into the body of the unit and has an electronic drive circuit to vary the frequency which can also be synchronised to the light source. Dippers can be attached to the generator by simply pushing them onto the stem. A hinged lid is situated above the tank and images of the waves are projected on to this for study. When access to the tank is required the lid is hinged out of the way. The sides of the tank are designed to absorb waves thus avoiding multiple reflections which could cause confused patterns.

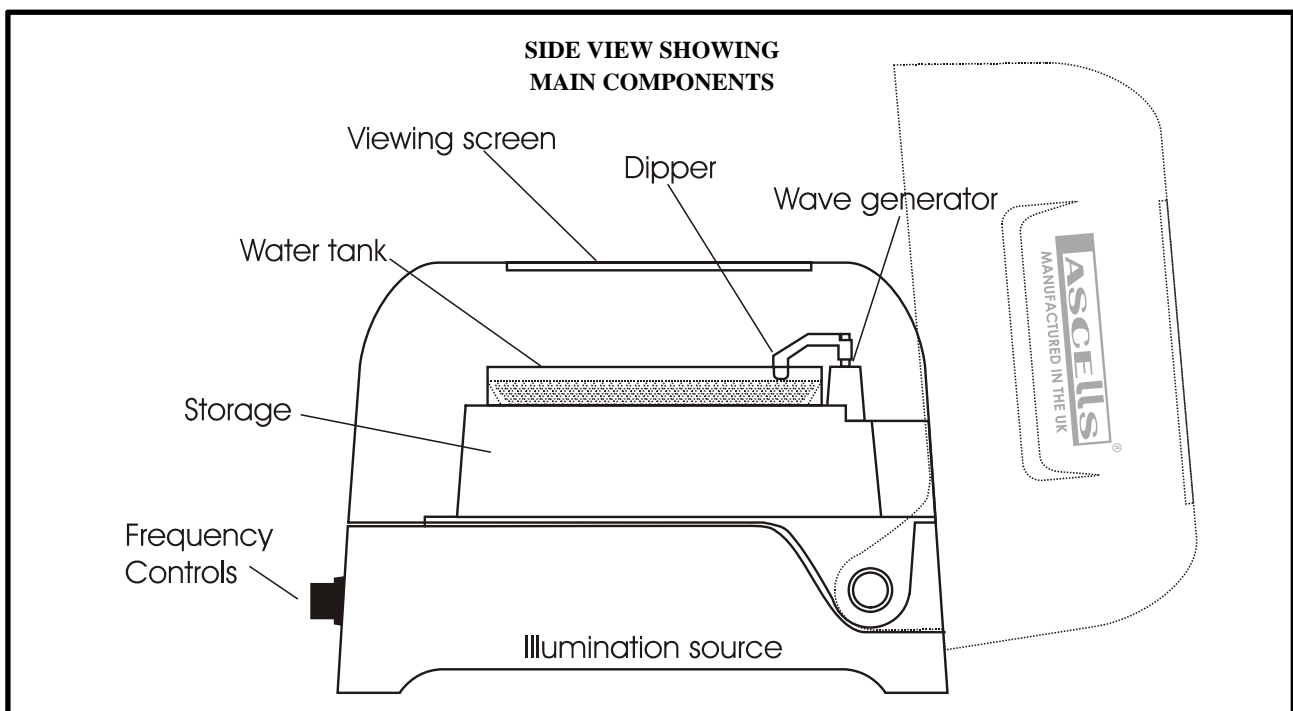

OBSERVE ALL NECESSARY PRECAUTIONS FOR STROBE ILLUMINATION

Take care to ensure that no user or observer of the apparatus is adversely affected by stroboscopic light.

SETTING UP:

- Place the unit on a level bench and connect the power supply lead to the side socket. Plug the power unit into a mains supply and switch on.
- Set the wave generator and strobe switches to OFF.
- Lift the hinged lid to gain access to the wave generator.
- Remove the accessories from the unit.
- Half fill the tank with clean water (A small amount of surfactant can help to reduce the surface tension of the water).
- The dippers are a friction fit on the stem. Install a dipper onto the generator stem and adjust until the dipper just touches the surface of the water.
- Switch on the waves and strobe and adjust as required.

ILLUMINATION:

The light source should be set to OFF for setting up purposes.

When set to SYNC the light flashes at the same frequency as the wave generator and produces perfectly stationary images.

When set to FREE the strobe frequency can be controlled independently of the waves. By choosing a frequency close to the wave frequency the wave patterns can be made to move slowly across the screen.

INVESTIGATIONS:

The various accessories allow different wave effects to be studied. Higher frequencies give shorter wavelengths with the waves closer together. Since the patterns can be made stationary, a sheet of tracing paper or OHP film may be placed on the viewing screen and drawings made for subsequent analysis. In all cases certain wavelengths give the better results than others – adjust the wave frequency to best demonstrate the phenomenon in question.

REFLECTION:

Use a plane wave dipper and metal L-plate in the tank. Observe the incident and reflected wave directions. Vary the plate angle to see the effect. The curved reflector can be used to demonstrate converging and diverging waves. A single point dipper generates circular waves and the reflection of these can also be studied.

DIFFRACTION:

Use a plane wave dipper and metal L-plate parallel to the waves. Diffraction around and behind the plate will be seen. If two L-plates are used with a narrow gap between them, circular waves will be seen generated at the gap.

INTERFERENCE:

Use the twin point dipper with nothing else in the tank. Constructive and destructive interference will be seen where the two sets of circular waves meet.

REFRACTION:

This effect relies on the different speeds of water waves in different depths of water. The effects are only seen when there is a significant difference in the depths. To achieve this one of the transparent shapes is submerged in the tank and the level of the water is reduced until there is just a film over the shape (a syringe will prove invaluable throughout for this purpose). We then have about 0.5mm depth above the shape and 8mm depth elsewhere, i.e. a ratio of about 16:1.

1. Place the 5 sided block at the back of the tank so that it presents an angle to plane waves. As the waves slow down in the shallow water they are refracted towards the normal.
2. Place the convex or concave lens shape in the tank. Again adjust the water depth until there is a thin film over the shape. With plane waves there is a converging or diverging effect respectively.

CARE MAINTENANCE AND GENERAL TIPS

1. At the end of the session carefully lift the tank from the unit, pour away the water and dry the tank with a soft tissue. Use non abrasive cloths to clean any of the tank surfaces.
2. The best waves are generated when the dipper just touches the water surface. This can be achieved by adjusting the dipper height or the water depth.
3. If you require further assistance please contact our technical team using the details below.

Lascells Ltd.,

Walkmill Business Park, Sutton Road,
Market Drayton, Shropshire. TF9 2HT
Tel 01630 657 801 Fax 01630 656726

www.lascells.com



EUROPEAN UNION
Investing in Your Future
European Regional
Development Fund 2007-13